

# Rigid Screen Screens



Management System  
EN ISO 13485:2016  
www.tuv.com  
ID 000075020

TOTAL ECLIPSE



■ CONFIGURE YOUR SPACES AS YOU WANT ■

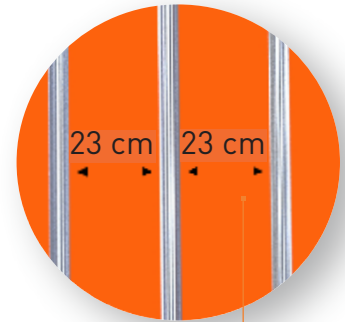

Optimised storage thanks to less wide panels

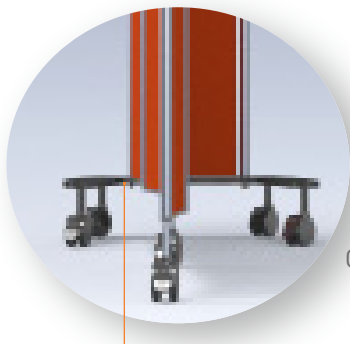

Optimum stability with the aluminium frame and wheels

Space saving when easily folded against the wall or the support

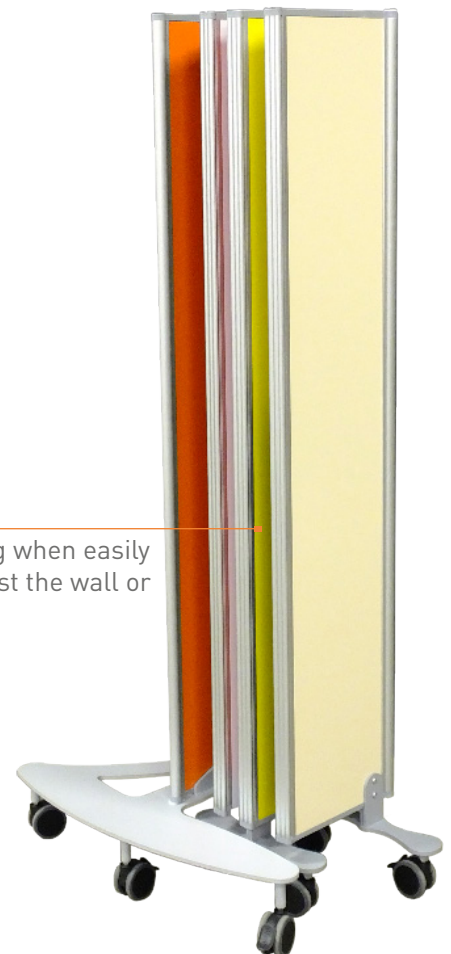

## Dimensions:



The Rigid'Eclipse are available in three different heights : 145cm / 165cm or 185cm.

Height	Number of panel	Length
145 cm	5	132 cm
165 cm	7	185 cm
185 cm	9	238 cm

## Technical Specifications

### Aluminium

Description	Aluminium foil Thermo-bound to a polyethylene core
Thickness	3,8 kg/m <sup>2</sup>
Density	3 mm
Impact resistance	50 kg/m <sup>2</sup>
Sound absorption	24 dB
Fireproof classification	M1
Cleaning	Manual disinfection, steam, nebulisation

### Colors



## Options

References	Designation
WALL1	Classic wall support
WALL2	Wall support with spacer 10 cm
MOBILE	Mobile support
CRISTAL	Translucent upper part
COLORS	To choose among 6 colors