

EN

TS15*

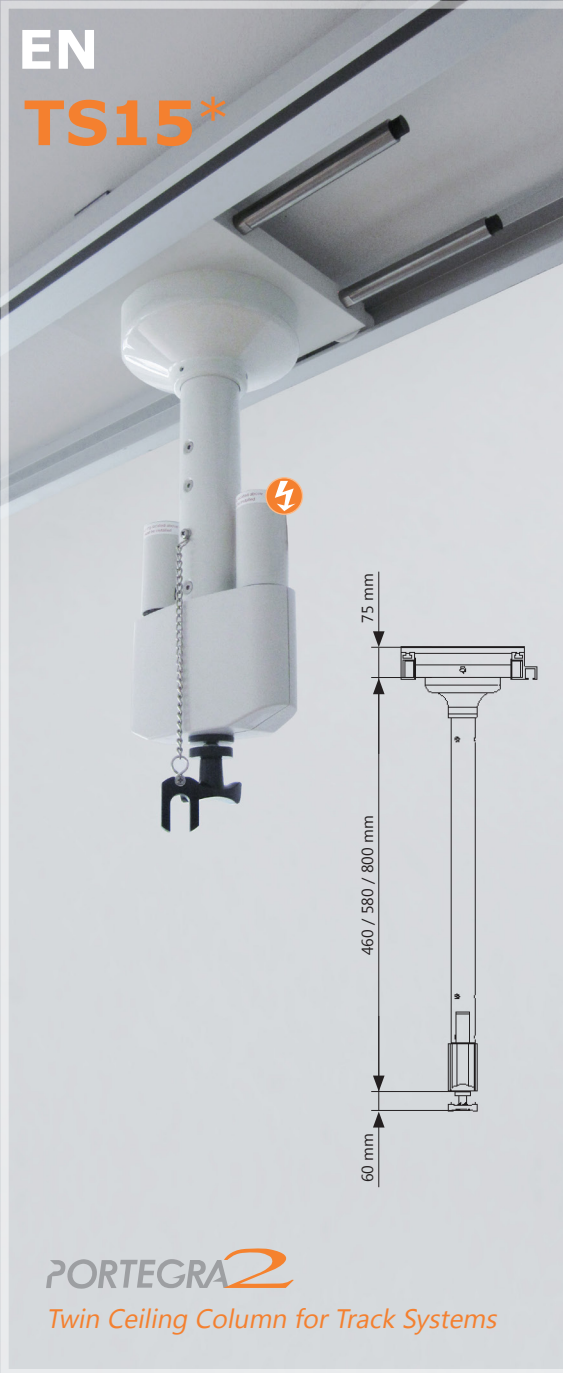

PORTEGRA²
Twin Ceiling Column for Track Systems

TS20*



PORTEGRA²
360° Ceiling Column for Track Systems

MAVIG



Carriage with two 18 cm (7.1 in) spacers with rubber buffer

Model Variants: TS15011/21/31 Twin Column with carriage plus spacer (please refer to table below for different lengths)
TS20311/21 360° Column with carriage plus spacer (please refer to table below for different lengths)

Made in Germany

IEC 60601-1

MAVIG Ceiling Columns with Carriage plus Spacer

Solid construction for maximum safety. Many years of development has led to MAVIG's unique steel columns. The proven construction, sturdy design, and numerous tests ensure the highest level of safety available. The patented brake mechanism is a standard for all support systems with a carriage. The brake holds the carriage at a fixed position inside the ceiling track, which provides additional safety during its use.

MAVIG columns are equipped standard with one electrical pin for a direct connection to a lamp.

- **Two 18 cm (7.1 in) spacers premounted to the carriage** to allow the use of two columns in one track without collisions (left/right versatile). Please note: Maximum two columns allowed for one track!
- **Each pin offers a 235° rotation** (360° for the lower pin of the 360° column)
- **One electrical connection:** One 3-pole sliding contact ⚡
- **Maximum spring arm net load:** 18.0 kg (39.7 lbs) per pin
- **Different column lengths* to match room height**

Article-No.	Twin Length*	Article-No.	360° Length*
TS15011	800 mm	TS20311	800 mm
TS15021	580 mm	TS20321	570 mm
TS15031	460 mm		

* Ceiling column lengths are measured from the top of the mounting flange to the bottom of the column structure. For a total length when installed, 75 mm needs to be added for the track and 60/80 mm for the brake handle.

MAVIG GmbH
X-Ray Protection and
Medical Suspension Systems

Stahlgruberring 5
81829 Munich
Germany

PO Box 82 03 62
81803 Munich
Germany

Phone +49 (0) 89 / 420 96 - 0
Fax +49 (0) 89 / 420 96 - 200
e-Mail info@mavig.com